



WIRELESS FOR
DYNAMIC MICROPHONES
AND PA/DJ SYSTEMS

U3 MICROPHONE WIRELESS SYSTEM

U3D DUAL WIRELESS SYSTEM FOR AUDIO

English Manual

CERTIFICATION

This Class B digital apparatus complies with Canadian ICES-003.

IC Caution: RSS-Gen Issue 4 December 2014" & "CNR-Gen 4e Décembre 2014:

This device complies with Industry Canada licence-exempt RSS standard(s).

Operation is subject to the following two conditions:

- (1) This device may not cause interference, and
- (2) This device must accept any interference, including interference that may cause undesired operation of the device.

Le présent appareil est conforme aux CNR d'Industrie Canada applicables aux appareils radio exempts de licence.

L'exploitation est autorisée aux deux conditions suivantes:

- (1) l'appareil ne doit pas produire de brouillage, et
- (2) l'utilisateur de l'appareil doit accepter tout brouillage radioélectrique subi, même si le brouillage est susceptible d'en compromettre le fonctionnement.

Radio Approvals:

FCC Part 15.249, FCC Part 15 B, RSS-210 (Canada), EN 300 440 (Europe), EN 301.489 (Europe), MIC Notice No.88 Appendix No. 43 (Japan)

FCC CERTIFICATION

THIS DEVICE COMPLIES WITH PART 15 OF THE FCC RULES.
OPERATION IS SUBJECT TO THE FOLLOWING TWO CONDITIONS:

- (1) THIS DEVICE MAY NOT CAUSE HARMFUL INTERFERENCE, AND
- (2) THIS DEVICE MUST ACCEPT ANY INTERFERENCE RECEIVED, INCLUDING INTERFERENCE THAT MAY CAUSE UNDESIRE OPERATION.

WARNING:

Changes or modifications not expressly approved in writing by Xvive may void the user's authority to operate this equipment.

RF EXPOSURE STATEMENT:

This transmitter must not be co-located or operated in conjunction with any other antenna or transmitter.

NOTE:

This equipment has been tested and found to comply with the limits for a Class B digital device, pursuant to part 15 of the

FCC Rules. These limits are designed to provide reasonable protection against harmful interference in a residential installation. This equipment generates, uses and can radiate radio frequency energy and, if not installed and used in accordance with the instructions, may cause harmful interference to radio communications. There is no guarantee that interference will not occur in a particular installation. If this equipment does cause harmful interference to radio or television reception, which can be determined by turning the equipment off and on, the user is encouraged to try to correct the interference by one or more of the following measures:

- Reorient or relocate the receiving antenna.
- Increase the separation between the equipment and receiver.
- Connect the equipment into an outlet on a circuit different from that to which the receiver is connected.
- Consult the dealer or an experienced radio/TV technician for help.

CAUTION
RISK OF ELECTRIC SHOCK
DO NOT OPEN



WARNING:

TO REDUCE THE RISK OF FIRE OR ELECTRIC SHOCK, DO NOT REMOVE SCREWS.
NO USER-SERVICEABLE PARTS INSIDE. REFER SERVICING TO QUALIFIED SERVICE PERSONNEL.

WARNING:

TO REDUCE THE RISK OF FIRE OR ELECTRIC SHOCK, DO NOT EXPOSE THE APPLIANCE TO RAIN OR MOISTURE.



Hereby, **SHENZHEN FZONE TECHNOLOGY CO., LTD**,
declares that this type of equipment is in compliance with the essential
requirements and other relevant provisions of Directive 2014/53/EU

SAFETY INSTRUCTIONS FOR LITHIUM-ION RECHARGEABLE BATTERIES

If abused or misused, the rechargeable batteries may leak. In extreme cases, they may even present a risk of explosion, fire, heat, smoke or gas. Xvive does not accept any liability for damage arising from abuse or misuse.

- Keep away from children.
- Only charge rechargeable batteries with chargers recommended by Xvive.
- Observe correct polarity.
- Pack/store charged rechargeable batteries so that the terminals cannot contact each other (danger of shorting out/fire hazard).
- Do not expose to moisture.
- Switch rechargeable battery-powered products off after use.
- Only charge rechargeable batteries at ambient temperatures between 10°C/50°F and 40°C/104°F.

- When not using rechargeable batteries for extended periods of time, charge them regularly (about every three months).
- Do not mutilate or dismantle.
- Do not heat above 60°C/140°F, e.g. do not expose to sunlight or throw into a fire.
- Immediately remove rechargeable batteries from obviously defective products.
- Do not continue to use defective rechargeable batteries.
- Only use rechargeable batteries specified by Xvive.
- Dispose of rechargeable batteries at special collection points or return them to your specialist dealer.
- Store the products in a cool and dry place at room temperature (approx. 20°C/68°F).
- Remove the rechargeable batteries if the products will not be used for extended periods of time.

INFORMATION ABOUT COLLECTION AND DISPOSAL OF OLD ITEMS AND USED BATTERIES

To protect our environment, please take old products and used batteries to proper collection places; and, in the EU, follow your national legislation and the Directives 2012/19/EU and 2006/66/EC.

When disposing of old products and batteries, please help to save valuable resources and prevent any possibilities of side effects on human health and the environment.

You can contact your local authority to find out how to dispose of old products and used batteries responsibly.

For product owners in the European Union:

If you want to discard electrical and electronic items, please contact your dealer or supplier for further information.

Information on Disposal in other Countries outside the European Union:

Please contact your local authorities or dealer for more information regarding the disposal of old items and used batteries.

The symbols shown below are valid only in the European Union. They indicate that you must not mix used electronic products and batteries with general household garbage.



Cd

**IMPORTANT SAFETY INSTRUCTIONS
PLEASE READ THESE INSTRUCTIONS
AND KEEP IN A SAFE PLACE**



WARNING:
BEFORE USING YOUR XVIVE U3/U3D,
CAREFULLY READ THE OPERATING INSTRUCTIONS.

1. Observe all instructions carefully in the U3/U3D manual.
2. Do not to perform service operations beyond those described in the U3/U3D manual. Service is required when the apparatus has been damaged in any way, such as:
 - Liquid has been spilled or objects have fallen into the apparatus
 - The unit has been exposed to rain or moisture
 - The unit does not operate normally or changes in performance in a significant way
 - The unit is dropped or the enclosure is damaged
3. Do not place near heat sources, such as radiators, heat registers, or appliances which produce heat.
4. Guard against objects or liquids entering the device.
Do not use or place unit near water.
5. Clean only with a dry cloth.
6. Only use attachments/accessories specified by the manufacturer.

ONE-YEAR LIMITED WARRANTY

Xvive Corporation Ltd. [Xvive] warrants our products to be free of defects in materials and workmanship in normal use for a period of one (1) year from the date of original purchase. Please visit www.xvive.com to register your new purchase. Xvive will, at its sole discretion, or in affiliation with our authorized retailers, repair or replace at no charge, any unit that is inspected by Xvive or an affiliated Xvive service center and deemed to be defective within the warranty period. This warranty is non-transferrable.

This warranty is only valid to the original purchaser, only when purchased "new-in-box" from an Authorized Xvive Dealer and with a valid proof of purchase bearing the purchase date.

Within the USA:

- All Xvive warranty claims should be made with the retailer from which the unit was purchased. This applies to both retail stores and online retailers.

Outside of the USA:

- For all warranty and non-warranty claims, the purchaser should contact the Authorized Xvive Retailer from which the unit was purchased within the country or province in which it was purchased for information on how to obtain warranty or non-warranty service.

This limited warranty does not cover the following:

- Products that have been modified in any way;
- Any products whose serial numbers have been altered or removed;
- Exterior cosmetic damage or damage to the finish due to misuse or normal wear and tear;
- Products that were purchased as "used", items listed as demo stock or refurbished items;
- Damage to the product or parts caused by improper storage by the user;
- Any freight charges (from or to the retailer);

ONE-YEAR LIMITED WARRANTY

- **Shipping Damage:**

- Shipping damage claims must be filed with the freight carrier (such as UPS, FedEx).
- Notify the freight carrier immediately of any shipping damage upon receipt of damaged items to begin the claim process.
- We also recommend reporting any shipping damage claim within (48) hours of receipt to the Authorized Retailer from which the item was purchased.
- Keep all original documents and packing materials until freight damage claim has a final resolution.

- **For units returned to Xvive USA:**

- The item must be returned in the same format in which it was purchased. If a system containing a transmitter and receiver was purchased, then both units will need to be returned together.
- The purchaser will pay all freight charges to return the original item to Xvive USA or its affiliated service centers.

- If the unit is deemed to be covered by this warranty, Xvive will ship the repaired or replacement unit to the purchaser free-of-charge and without any additional freight charges.
- If the unit is deemed to NOT be covered by this warranty, other charges plus return freight charges will apply. EXCEPT AS EXPRESSLY SET FORTH ABOVE IN THIS LIMITED WARRANTY, XVIVE MAKES NO OTHER EXPRESS OR IMPLIED WARRANTIES TO THE EXTENT PERMITTED BY LAW. XVIVE ASSUMES NO LIABILITY FOR PROPERTY DAMAGE RESULTING FROM FAILURE OF THIS PRODUCT NOR ANY LOSS OF INCOME, SATISFACTION, OR DAMAGES ARISING FROM THE LOSS OF USE OF SAME DUE TO DEFECTS OR AVAILABILITY OF SAME DURING SERVICE. THIS WARRANTY GIVES YOU SPECIFIC LEGAL RIGHTS AND YOU MAY ALSO HAVE OTHER RIGHTS WHICH VARY FROM STATE TO STATE OR BY COUNTRY OR PROVINCE.

For warranty inquiries not covered in this policy, please contact support@xvive.com

U3 SET: PRODUCT INTRODUCTION

- The 2.4 GHz wireless band is optimal for dynamic microphone and PA wireless systems, and is approved for use worldwide.
- Less than 5 ms latency
- Up to 6 systems can operate simultaneously in the same location on separate channels
- Broad 20 Hz – 20 kHz frequency response
- Up to 90-foot wireless range (actual range depends on RF signal absorption, reflection and interference)
- 5 hours of battery life (rechargeable battery for both transmitter and receiver)
- Works with XLR-output dynamic and battery-powered-condenser microphones
- Mic mode for microphones and Line mode for other audio gear such as mixers
- High-resolution 24-bit / 48 kHz audio
- Dynamic range: 110 dB
- Signal-to-noise ratio: 110 dB
- U3 is a simple, reliable, great-sounding and affordable wireless solution for taking the tangle and inconvenience of cables out of your microphone setup.

U3: PACKAGE DETAILS

| | |
|----------------|----|
| U3 Transmitter | x1 |
| U3 Receiver | x1 |
| USB Cable | x1 |
| Manual | x1 |
| Bag | x1 |

U3D SET: PRODUCT INTRODUCTION

- Includes the U3 microphone wireless system (2 sets)
- The 2.4 GHz wireless band is optimal for dynamic microphone and PA wireless systems, and is approved for use worldwide.
- Less than 5 ms latency
- Up to 6 systems can operate simultaneously in the same location on separate channels
- Broad 20 Hz – 20 kHz frequency response
- Up to 90-foot wireless range (actual range depends on RF signal absorption, reflection and interference)
- 5 hours of battery life (rechargeable battery for both transmitter and receiver)
- Mic mode for microphones and Line mode for other audio gear such as mixers
- Works with XLR-output dynamic and battery-powered-condenser microphones
- High-resolution 24-bit / 48 kHz audio
- Dynamic range: 110 dB
- Signal-to-noise ratio: 110 dB
- Two Transmitter + Receiver sets:
With a stereo PA/DJ system with powered speakers, connect

the left PA XLR output to the left speaker and right output to right speaker); For a dual mono setup, connect a transmitter to the PA/DJ XLR output, connect receivers to speaker one and speaker two, and set all three units to the same channel; Microphone application: connect two dynamic microphones to a mixer or other XLR-input audio device

- U3D is a simple, reliable, great-sounding and affordable wireless solution for taking the tangle and inconvenience of cables out of your PA/DJ sound system.

U3D: PACKAGE DETAILS

| | |
|--------------------------------------|----|
| U3 Transmitter | x2 |
| U3 Receiver | x2 |
| USB Cable | x2 |
| XLR female to XLR male adapter | x1 |
| Manual | x1 |
| Bag | x2 |

QUICK START: MICROPHONE APPLICATIONS

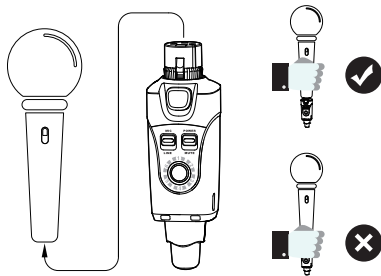

1. Plug your XLR dynamic microphone or battery-powered condenser microphone into the U3 Transmitter.

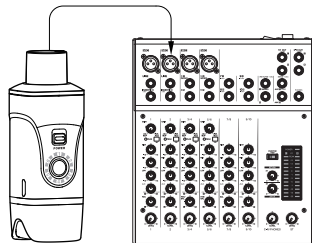

2. Plug the Receiver into the desired XLR channel input of your Mixer.

QUICK START: MICROPHONE APPLICATIONS (CONT.)

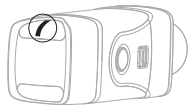
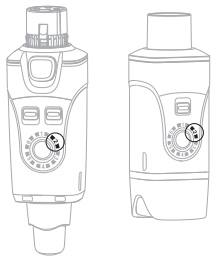

3. Turn on the Transmitter and the Receiver and check that they are both set to the same channel.

4. After connecting successfully, the LED lights on the Receiver will stay on.

5. Check the connection by talking through the microphone.

QUICK START: MONO CONNECTION TO A POWERED SPEAKER

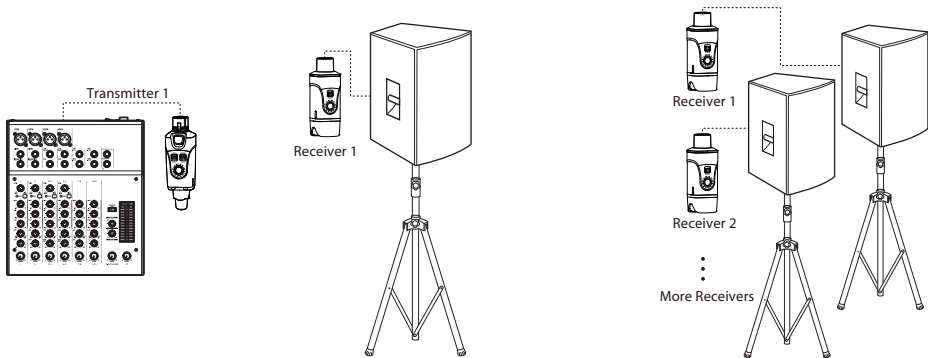

1. Connect the Transmitter to a Main or Aux XLR output of the mixer or other audio source.

2. Connect the Receiver to the XLR input of a powered PA loudspeaker or monitor.

3. Set the Receiver to the same channel as the Transmitter. The Transmitter can be paired with two or more receivers, as long as they are all set to the same channel.

QUICK START: TWO U3 SETS FOR STEREO / DUAL MONO PA APPLICATIONS

For stereo PA/DJ systems, connect Transmitter #1 to the left main XLR output of the mixer, and connect Receiver #1 to the XLR input of the left main loudspeaker. When you power them on, set them both to the same channel. Then, connect Transmitter #2 to the right main XLR output of the mixer, and connect Receiver #2 to the XLR input of the right main loudspeaker. When you power them on, set them both to the same channel, which must be a different channel than set #1.

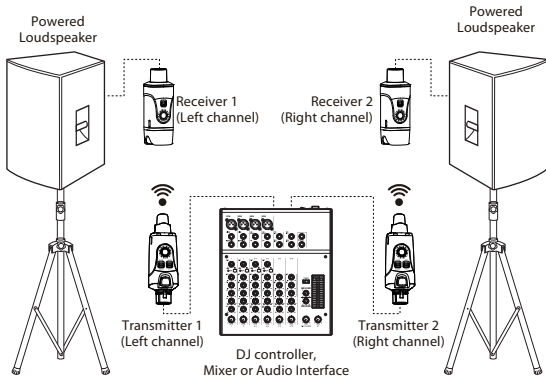

For mono PA/DJ systems, connect Transmitter #1 to the mono main XLR output of the mixer, and connect Receiver #1 to the XLR input of one of the main loudspeakers. When you power them on, set them both to the same channel. Then, connect Receiver #2 to the XLR input of the second main loudspeaker. When you power it on, set it to the same channel as set #1. Both speakers will receive the same mono signal.

OVERVIEW: U3 TRANSMITTER

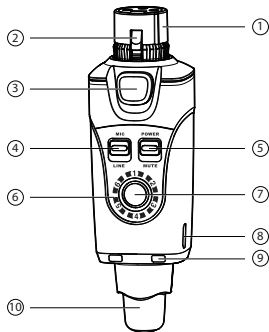

- ① **Mic In:** XLR microphone input jack
- ② **Spring:** Circumferential grounding spring for providing a reliable connection to the male XLR plug
- ③ **Mic Lock:** secures transmitter to the microphone
- ④ **Input mode / level switch:**
MIC = 0 dB input LINE = -10 dB input
- ⑤ **Power switch:** switches unit on/off
- ⑥ **Channel status LED:** indicates selected channel
- ⑦ **Channel switch:** selects channels 1-6
- ⑧ USB charging port
- ⑨ **Power status LED:**
LED off = 100% ~ 30%
Solid red = 29% ~ 11%
Flickering red = less than 10%
- ⑩ **Antenna**

OVERVIEW: U3 RECEIVER

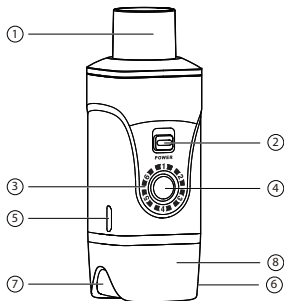

- ① **XLR OUT:** XLR output jack
- ② **Power switch:** switches the unit on and off
- ③ **Channel status LED:** indicates selected channel
- ④ **Channel switch:** selects channels 1-6
- ⑤ **USB Port:** connects to 5V USB power for charging the battery
- ⑥ **RF Status LED:**
 - ON = Transmitter is on and connection is established
 - Flashing = Signal connection interference
 - OFF = Transmitter is off or unlinked
- ⑦ **Power status LED:**
 - LED off = 100% ~ 30%
 - Solid red = 29% ~ 11%
 - Flickering red = less than 10%
- ⑧ **Antenna**

SPECIFICATIONS

U3 MICROPHONE WIRELESS SYSTEM

| | |
|------------------------------|---|
| Tuning bandwidth | 2400 – 2483.5 MHz |
| Wireless signal range | Up to 90 ft. (actual range depends on RF signal absorption, reflection and interference) |
| Audio frequency response | 20 Hz – 20 kHz (-3dB), dependent on microphone type / input signal |
| Dynamic range | 110 dB |
| Battery life | Up to 5 hours |
| RF sensitivity | -88 dBm |
| Total harmonic distortion | 0.2% |
| RF output power | 10 mW E.I.R.P. max |
| Operating temperature range | -18°C to 57°C (battery characteristics may limit this range) |
| Channel count | Up to 6 channels (and U3 sets) can be used simultaneously |
| Charging voltage and current | 5V 2A |

| | U3 TRANSMITTER | U3 RECEIVER |
|----------------------------|---|---------------------------------------|
| Dimensions | 31 x 29 x 98 mm | 31 x 29 x 81 mm |
| Weight | 93 g | 92 g |
| Housing | Molded plastic and cast metal | Molded plastic and cast metal |
| Battery | 3.7V Rechargeable Li-ion, 860 mA | 3.7V Rechargeable Li-ion, 860 mA |
| Impedance | Input: 15 k Ω (1 kHz) | Output: 470 Ω (1 kHz) |
| Audio input connector | Balanced XLR male | |
| Audio output connector | | Balanced XLR female |
| Maximum input level | Mic mode: 2.8 Vp-p / Line mode: 7 Vp-p | |
| Maximum output level | | 2.8 Vp-p |
| Gain adjustment range | Mic mode: 0 dB / Line mode: -10 dB | |
| Battery life | Up to 5 hours | Up to 5 hours |
| Microphone types supported | XLR-output dynamic and battery-powered XLR-output condenser | |
| Antenna impedance | 50 Ω | 50 Ω |
| Antenna type | 1/4 wave sleeve dipole, non-removable | 1/4 wave sleeve dipole, non-removable |
| Number of antennas | 1 | 2 |

BATTERIES AND CHARGING

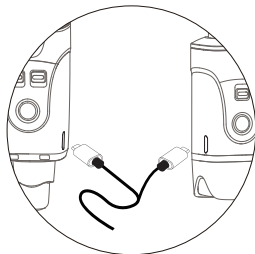

Connect to U3 units

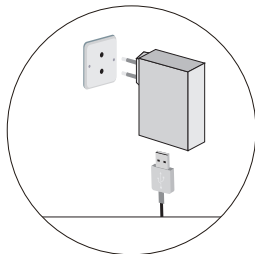

Connect to 5V USB power

Note:

Turn off the power switch while charging.

Please do not use U3 when charging, as this may reduce battery life.

CHARGING TIME

BATTERY LIFE

0:15

30 min

0:30

1 hour

1:00

2 hours

2:30

5 hours

* Always store U3 transmitter and receiver at room temperature.

* When storing the units unused for longer periods, please check the battery state regularly and charge if necessary.

2.4 GHz WIRELESS OVERVIEW AND INTERFERENCE

U3 operates on the 2.4 GHz ISM band, which is also used by Wi-Fi, Bluetooth, and other wireless devices. 2.4 GHz is an open band and, as such, does not require a license to be used worldwide.

Tips and Methods to Improve Wireless System Performance:

- 1) Keep more than 3 metres of distance between the U3 receiver unit and Wi-Fi transmitters, such as routers.
- 2) If you experience interference from Wi-Fi devices in the vicinity, try changing to a different channel on the U3 transmitter and receiver.
- 3) If necessary, shorten the distance between the transmitter and receiver units.

2.4 GHz Frequency Tables

| | |
|-----------|------------------------------|
| CHANNEL 1 | 2402 MHz, 2480 MHz, 2482 MHz |
|-----------|------------------------------|

| | |
|-----------|------------------------------|
| CHANNEL 2 | 2408 MHz, 2472 MHz, 2474 MHz |
|-----------|------------------------------|

| | |
|-----------|------------------------------|
| CHANNEL 3 | 2416 MHz, 2464 MHz, 2466 MHz |
|-----------|------------------------------|

| | |
|-----------|------------------------------|
| CHANNEL 4 | 2434 MHz, 2440 MHz, 2442 MHz |
|-----------|------------------------------|

| | |
|-----------|------------------------------|
| CHANNEL 5 | 2427 MHz, 2448 MHz, 2450 MHz |
|-----------|------------------------------|

| | |
|-----------|------------------------------|
| CHANNEL 6 | 2422 MHz, 2456 MHz, 2458 MHz |
|-----------|------------------------------|

* Channels 1-4 of the Xvive U2 Guitar Wireless System occupy the same frequencies as channels 1-4 on the U3 Microphone Wireless System and U3C Condenser Microphone Wireless System.

Combined maximum number of U2/U3/U3C sets that can be used simultaneously in one location is six.

TROUBLESHOOTING

| ISSUE | SOLUTION |
|--|--|
| No sound | <ul style="list-style-type: none">• Make sure that the U3 Transmitter and Receiver are set to the same channel.• Check that the U3 Receiver's RF LED is on.• Check that the microphone is properly connected to the U3 Transmitter, and turned on if necessary• Check that the Transmitter and Receiver power switches are both turned on.• Note: Receivers can be paired with only one Transmitter at a time. |
| Distortion or faint sound | <ul style="list-style-type: none">• Make sure the input/gain mode is correctly set to "Line" (for an audio device such as a mixer) or "Mic" (for a microphone).• Adjust the output signal from the transmitting device (turn up if too faint, turn down if distorting) |
| Signal instability: RF LED flickering, or off completely | <ul style="list-style-type: none">• See "Tips and methods to improve wireless system performance" on page 20 |
| Unable to switch the channel | <ul style="list-style-type: none">• The channel switch locks after 15 seconds. Double-click the channel button to unlock and reset. |
| Multiple connections | <ul style="list-style-type: none">• One transmitter can connect with two or more receivers; but receivers can only accept signal from one transmitter. |

APPLICATION OVERVIEW

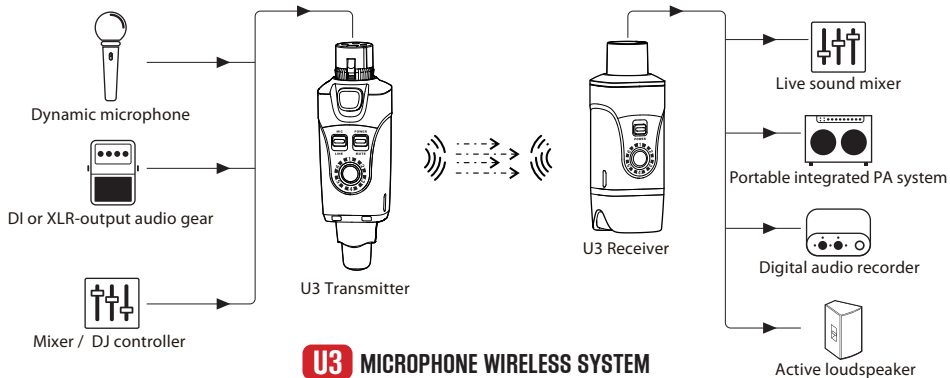

U3 MICROPHONE WIRELESS SYSTEM

U3D DUAL WIRELESS SYSTEM FOR AUDIO
For PA/DJ Systems with active speakers, and Dynamic Microphones



MADE IN CHINA

SHENZHEN FZONE TECHNOLOGY CO., LTD.

2nd floor, Building 12, Xicheng Industrial Area, Xixiang Town,
Baoan District, Shenzhen Guangdong China. 518101

E-mail: support@xvive.com

www.xvive.com

CHINA PATENT NUMBERS ZL 2016 3 0165464.8